

DOOR NUMBER	QTY	OPENING		MODEL	GA.	"A"	"B"	"C"	"D"	"E"	"F"	"G"	"H"	"J"	MOUNT TYPE	OPER.	DRIVE	JAMB TYPE	GUIDE	JOB:		
		WIDTH	HEIGHT																			
																					DISTRIBUTOR:	
																					CONTRACTOR:	
																					ARCHITECT:	NR:2901852

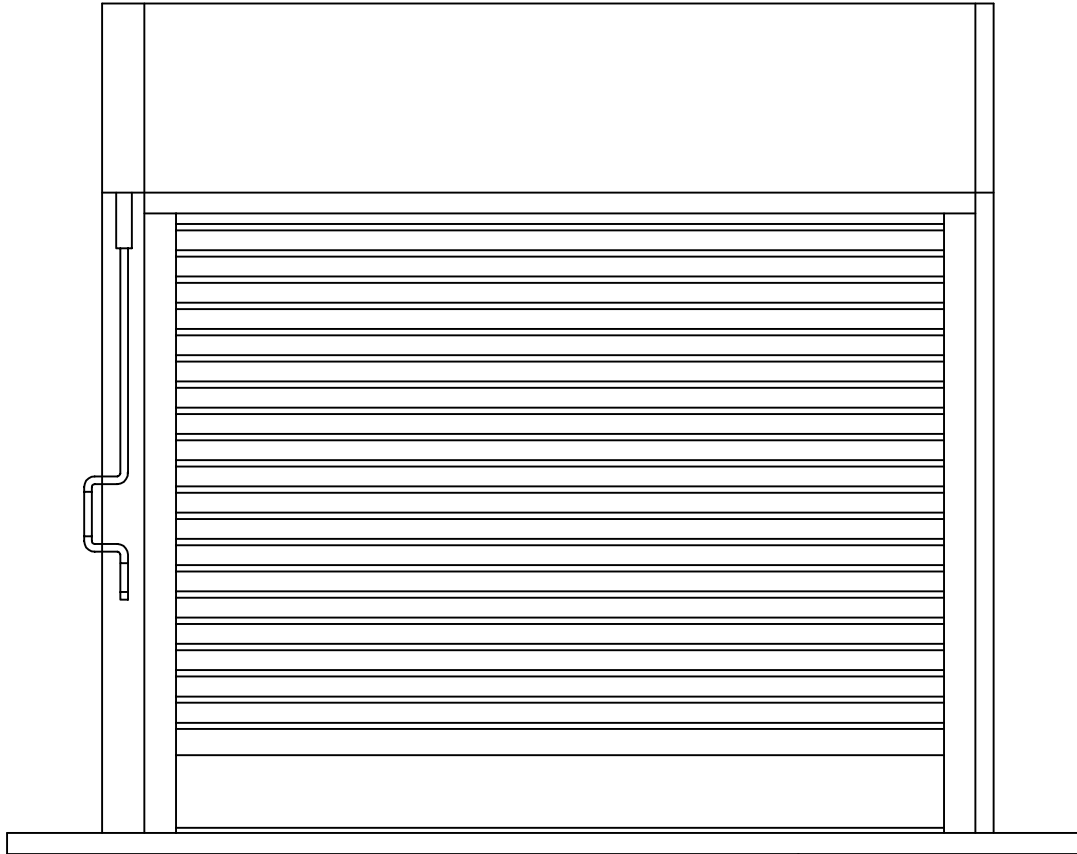

DURASHUTTER

DURASHUTTER CA
BETWEEN JAMB MOUNT
CRANK OPERATION



"ELEVATION"

COUNTER TOP
BY OTHERS

LEFT HAND DRIVE
(SHOWN)

RIGHT HAND DRIVE

DOORS SHALL BE ROLLING STEEL MODEL DURACURTAIN "SELECT" (COUNTER SHUTTER) AS MANUFACTURED BY RAYNOR GARAGE DOORS.

BARREL- STRUCTURAL STEEL PIPE, MINIMUM 4-1/2"(114.3mm) O.D. X.120" (3.0mm) WALL THICKNESS AND DESIGNED TO LIMIT MAXIMUM DEFLECTION, UNDER LOAD, TO .03"(0.76mm) PER FOOT OF SPAN.

SPRING COUNTERBALANCE- THE CURTAIN SHALL BE COUNTERBALANCED BY MEANS OF OIL TEMPERED, HELICAL TORSION SPRINGS, GREASE- PACKED AND MOUNTED ON A SINGLE CONTINUOUS STEEL TORSION SHAFT. SPRINGS SHALL BE COMPRESSION SPRING DESIGN TO FACILITATE ANY COUNTERBALANCE MAINTENANCE. CAST IRON SPRING ANCHORS SHALL TRANSFER FULL SPRING LOADING TO THE BARREL.

BRACKETS- 10 GAUGE GALVANIZED STEEL WITH FLANGED MOUNTING SURFACE FOR HOOD ATTACHMENT. INSIDE SURFACE SHALL BE FLUSH WITH GUIDE GROOVE. DRIVE SIDE BRACKET SHALL BE FITTED WITH A SEALED BALL BEARING FOR CONTINUED PERFORMANCE.

CRANK- BY MEANS OF WORM GEARBOX WITH REMOVABLE HANDLE.

MODEL CA

CURTAIN- SHALL BE INTERLOCKING, FLAT FACED, EXTRUDED ALUMINUM (6063-T5) SLATS .05"(1.3mm) THICK. BOTTOM OF CURTAIN TO BE EXTRUDED ALUMINUM (6063-T5) HAVING A HOLLOW RECTANGULAR CROSS SECTION WITH A VINYL ASTRAGAL.

GUIDES- SHALL BE EXTRUDED ALUMINUM (6063-T5) WITH WOOL PILE INSERTS ON BOTH SIDES, AND WITH REMOVABLE BELLMOUTH CURTAIN STOPS.

HOOD & SIDE COVER- SHALL BE .04"(1.0mm) THICK ALUMINUM. HOOD TO HAVE ROLLED EDGES TO PROVIDE RIGIDITY.

FINISH - GUIDES, SLATS, BOTTOM BAR, SIDE COVERS AND HOOD TO BE CLEAR ANODIZED 204-R1 FINISH.

- LOCKING- SLIDE BOLT TO ENGAGE GUIDE WITH PROVISION FOR PADLOCK. (PADLOCK BY OTHERS) QUANTITY REQUIRED
- LOCKING- FIVE PIN TUMBLER CYLINDER WITH LOCK BARS TO ENGAGE THE GUIDE. QUANTITY REQUIRED
- LOCK-OPERABLE FROM INTERIOR ONLY.
- LOCK-OPERABLE FROM EXTERIOR ONLY.
- LOCK-OPERABLE FROM BOTH INTERIOR AND EXTERIOR

DOOR NUMBER	QTY	OPENING		MODEL	GA.	"A"	"B"	"C"	"D"	"E"	"F"	"G"	"H"	"J"	MOUNT TYPE	OPER.	DRIVE	JAMB TYPE	GUIDE	JOB:			
		WIDTH	HEIGHT																				
																						DISTRIBUTOR:	
																							CONTRACTOR:
																							ARCHITECT:
																					NR: 2901852		

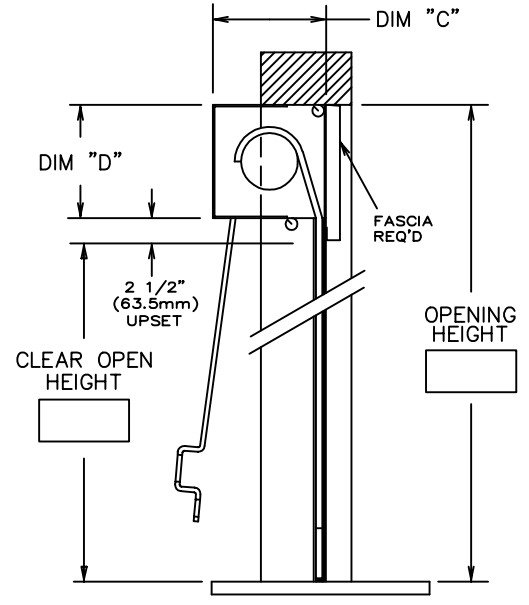

"SECTION THRU-OPENING"

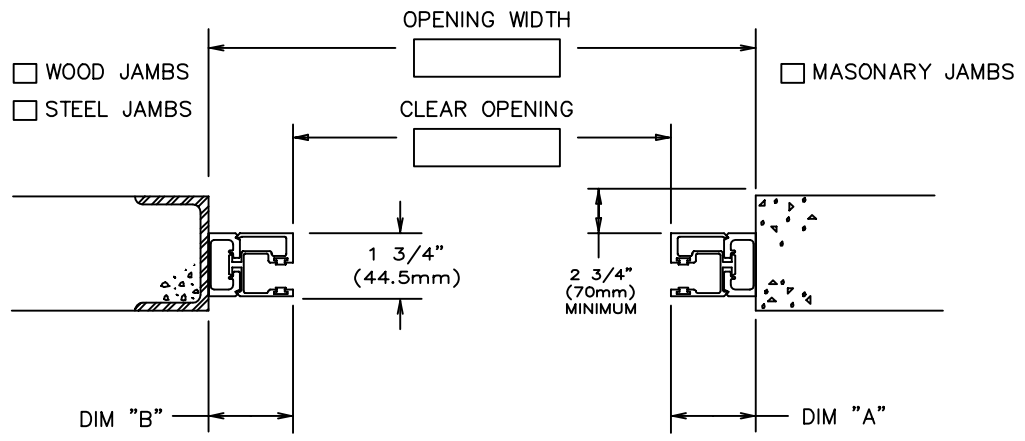

"GUIDE DETAIL"

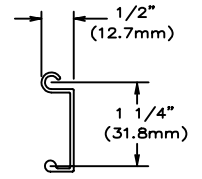

SLAT MODEL
MODEL CA