

DOOR NUMBER	QTY	OPENING		MODEL	GA.	"A"	"B"	"C"	"D"	"E"	"F"	"G"	"H"	"J"	MOUNT TYPE	OPER.	DRIVE	JAMB TYPE	GUIDE	JOB:	
		WIDTH	HEIGHT																		
																				DISTRIBUTOR:	
																				CONTRACTOR:	
																				ARCHITECT:	

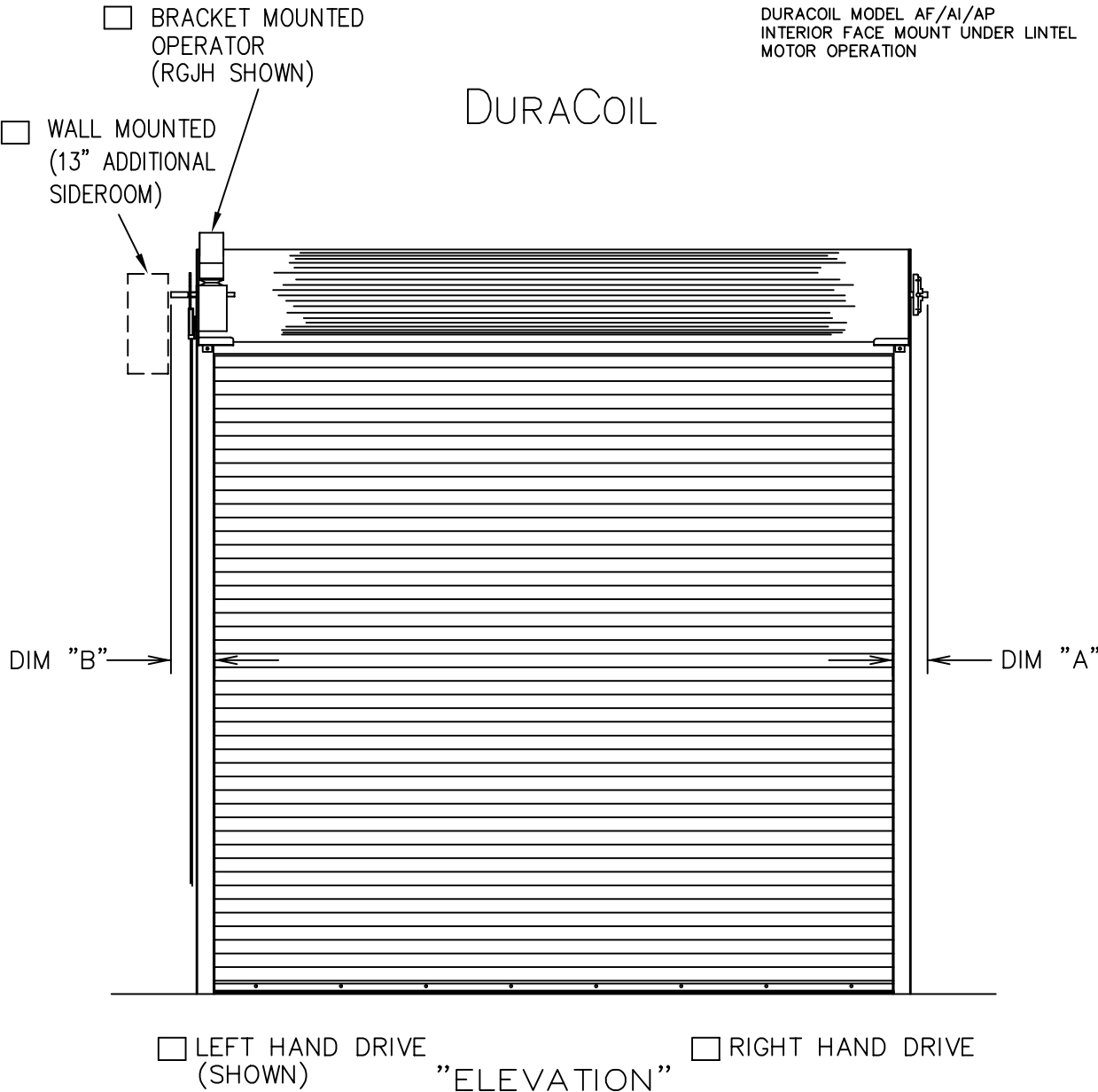

DURACOIL MODEL AF/AI/AP
 INTERIOR FACE MOUNT UNDER LINTEL
 MOTOR OPERATION

DURACOIL

DOORS SHALL BE ROLLING STEEL MODEL DURACOIL "STANDARD" (STANDARD SERVICE DOOR) AS MANUFACTURED BY RAYNOR GARAGE DOORS.

BRACKETS- STEEL PLATES, MIN. 3/16"(4.8mm) THICK, BOLTED TO GUIDES FOR MOUNTING CURTAIN AND BARREL ASSEMBLY. DRIVE SIDE BRACKET SHALL BE FITTED WITH A SEALED BALL BEARING FOR LONG LIFE.

BARREL- STRUCTURAL STEEL PIPE, MINIMUM 4-1/2"(114.3mm) O.D.X.120" (3.0mm) WALL THICKNESS AND DESIGNED TO LIMIT MAXIMUM DEFLECTION, UNDER LOAD, TO .03"(0.76mm) PER FOOT OF SPAN.

SPRING COUNTERBALANCE- THE CURTAIN SHALL BE COUNTERBALANCED BY MEANS OF OIL TEMPERED, HELICAL TORSION SPRINGS, GREASE-PAKED AND MOUNTED ON A SINGLE CONTINUOUS STEEL TORSION SHAFT. SPRINGS SHALL BE COMPRESSION SPRING DESIGN TO FACILITATE ANY COUNTERBALANCE MAINTENANCE. CAST IRON SPRING ANCHORS SHALL TRANSFER FULL SPRING LOADING TO THE BARREL.

HOOD- SHALL BE 24 GA. COMMERCIAL QUALITY HOT-DIPPED GALVANIZED STEEL. HOOD TO HAVE ROLLED EDGES TO PROVIDE RIGIDITY.

GUIDES- STRUCTURAL STEEL ANGLES, MIN. 3/16"(4.8mm) THICK. TOP OF GUIDE ANGLES FLARED AND PROVIDED WITH 4 REMOVABLE CURTAIN STOPS.

WINDLOAD- 20 LB./SQ. FT. STANDARD. UNLESS OTHERWISE NOTED.

MODEL AF

CURTAIN- INTERLOCKING SLATS ROLLFORMED FROM ALUMINUM 5005H34, ETCHED AND CLEAR ANODIZED 204R1 ON BOTH SIDES. MALLEABLE IRON GALVANIZED ENDLOCKS FASTENED TO ALTERNATE SLATS WITH TWO ZINC PLATED RIVETS PER LOCK, ELIMINATES LATERAL MOVEMENT AND PREVENT SLATS FROM WEARING AT SURFACES COMING IN CONTACT WITH GUIDES. BOTTOM OF CURTAIN SHALL BE REINFORCED WITH TWO ALUMINUM ANGLES, MIN. 2"x2"x3/16"(50.8mmX50.8mmX4.8mm). SINGLE CONTACT ASTRAGAL.

MODEL AI

CURTAIN -INSULATED- INTERLOCKING SLATS ROLLFORMED FROM ALUMINUM 5005H34 ETCH AND CLEAR ANODIZED ON BOTH SIDES TO 201R1. EACH SLAT SHALL HAVE A 3/4" (19.1mm) THICK, POLYISO FOAMBOARD CORE PLACED WITHIN THE FULL LENGTH OF THE SLAT. BACKING COVER TO BE ALUMINUM EXTRUDED .02" THICK. MALLEABLE IRON GALVANIZED ENDLOCKS FASTENED TO ALTERNATE SLATS WITH 2 ZINC PLATED STEEL RIVETS PER ENDLOCK. ELIMINATES LATERAL MOVEMENT AND PREVENTS THE SLATS FROM WEARING AT SURFACES COMING IN CONTACT WITH GUIDES. BOTTOM OF CURTAIN SHALL BE REINFORCED WITH AN ALUMINUM EXTRUDED T- SHAPED BOTTOM BAR. SINGLE CONTACT ASTRAGAL. THE CURTAIN "U" VALUE IS .16 AND "R" VALUE IS 6.24. (SPECIFICATIONS REFLECT CALCULATED CHARACTERISTICS OF CORE MATERIAL).

MODEL AP

CURTAIN- SHALL CONSIST OF INTERLOCKING FLAT SLATS ROLL FORMED FROM NOT LESS THAN .04" (1.0mm) THICK ALUMINUM AND PUNCHED WITH A SERIES OF HOLES ACROSS THEIR ENTIRE LENGTH, PROVIDING 31% OPEN AREA PER SQUARE FOOT OF DOOR. BOTTOM OF CURTAIN SHALL BE REINFORCED WITH TWO ALUMINUM ANGLES, MINIMUM 2"x2"x3/16" (50.8mmX50.8mmX4.8mm). SINGLE CONTACT BOTTOM ASTRAGAL.

- LOCKING- SLIDE BOLT TO ENGAGE GUIDE WITH PROVISION FOR PADLOCK. (PADLOCK BY OTHERS) QUANTITY REQUIRED
- LOCKING- FIVE PIN TUMBLER CYLINDER WITH LOCK BARS TO ENGAGE THE GUIDE. QUANTITY REQUIRED
- LOCK-OPERABLE FROM INTERIOR ONLY.
- LOCK-OPERABLE FROM EXTERIOR ONLY.

DOOR NUMBER	QTY	OPENING		MODEL	GA.	"A"	"B"	"C"	"D"	"E"	"F"	"G"	"H"	"J"	MOUNT TYPE	OPER.	DRIVE	JAMB TYPE	GUIDE	JOB:	
		WIDTH	HEIGHT																		
DISTRIBUTOR:																					
CONTRACTOR:																					
ARCHITECT:																					

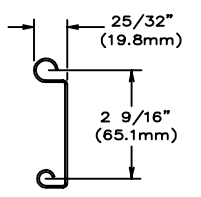

SLAT MODEL "AF"

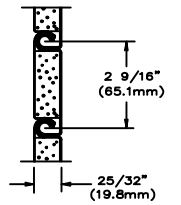

SLAT MODEL "AI"

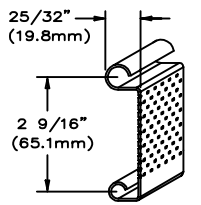

SLAT MODEL "AP"

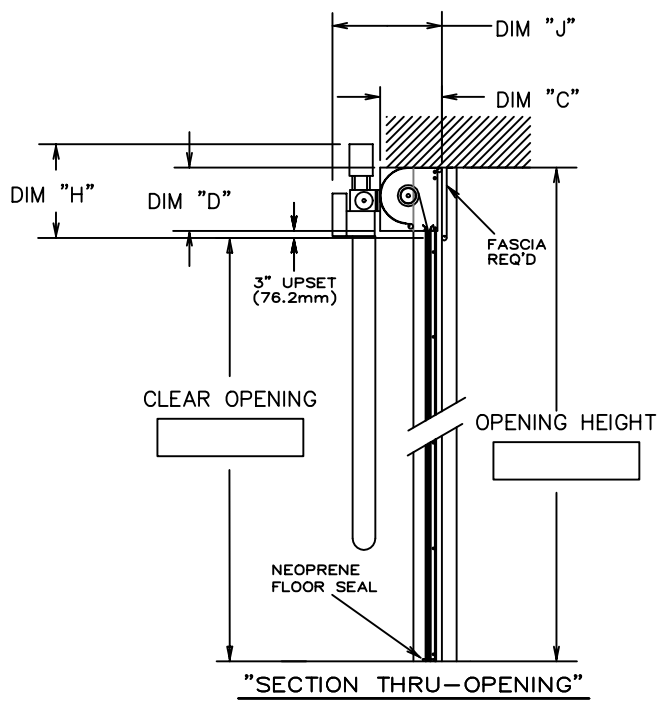

- RAYNOR POWERHOIST BASIC (PHBJR) 1/2 H.P., 115 VOLT, SINGLE PHASE
- RAYNOR POWERHOIST BASIC (PHBHR) 1/2 H.P., 115 VOLT, SINGLE PHASE
- RAYNOR POWERHOIST BASIC (PHBJ) 1/2 H.P., 115 VOLT, SINGLE PHASE
- RAYNOR POWERHOIST BASIC (PHBJH) 1/2 H.P., 115 VOLT, SINGLE PHASE
- RAYNOR POWERHOIST STANDARD (RBJ) ___ H.P., ___ VOLT, ___ PHASE
- RAYNOR POWERHOIST STANDARD (RBJH) ___ H.P., ___ VOLT, ___ PHASE
- RAYNOR POWERHOIST OPTIMA (RGJH) ___ H.P., ___ VOLT, ___ PHASE
- WIRING TYPE—SR2 WIRING, MOMENTARY CONTACT OPEN/CLOSE/STOP. SAFETY EDGE TO REVERSE.
- WIRING TYPE—SPECIAL (NOT AVAILABLE WITH PHBT OPERATORS) SPECIFY SPECIAL WIRING TYPE _____
- PNEUMATIC SAFETY EDGE TO REVERSE COIL CORD OR CABLE TAKE UP REEL
- ELECTRIC SAFETY EDGE TO REVERSE
- THRU—BEAM PHOTO EYES

ANSI/UL325 REQUIRES THE MOTOR OPERATOR BE MOUNTED A MINIMUM OF 8' ABOVE THE FLOOR OR GUARDING OF THE MOTOR OPERATOR TO PREVENT INJURY.(GUARDS BY OTHERS).

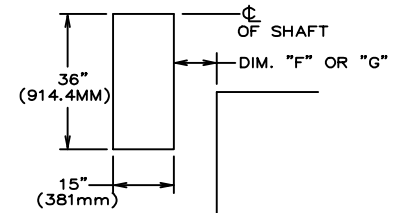

"OPERATOR MTG. PAD"
(FOR WALL MOUNTED OPERATORS ONLY)

