

DOOR NUMBER	QTY	OPENING		MODEL	GA.	"A"	"B"	"C"	"D"	"E"	"F"	"G"	"H"	"J"	MOUNT TYPE	OPER.	DRIVE	JAMB TYPE	GUIDE	JOB:	
		WIDTH	HEIGHT																		
																					DISTRIBUTOR:
																					CONTRACTOR:
																					ARCHITECT:
																					NR:2902552

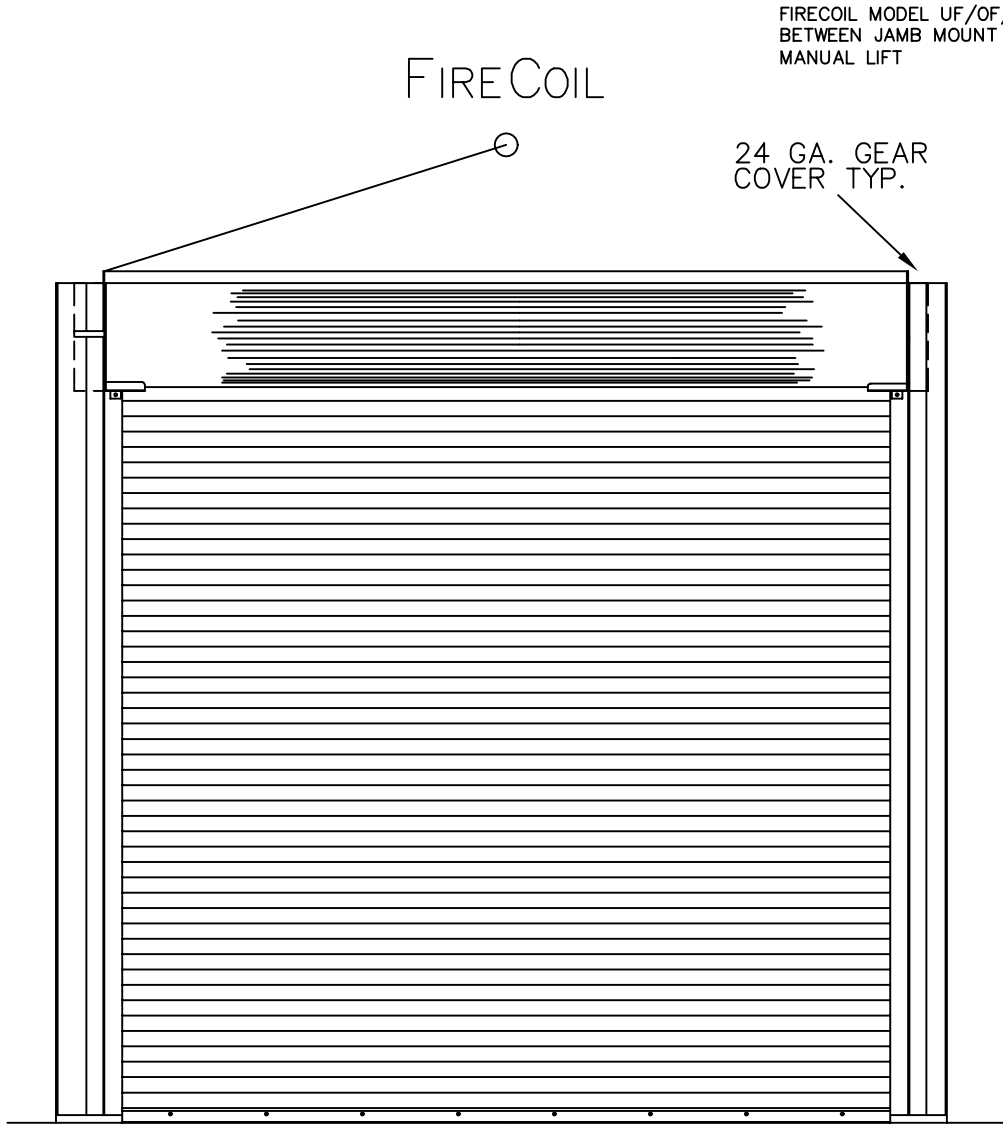

FIRECOIL MODEL UF/OF/US/OS/LL/OL
BETWEEN JAMB MOUNT ABOVE LINTEL
MANUAL LIFT

FIRE COIL

24 GA. GEAR
COVER TYP.

DOORS SHALL BE ROLLING STEEL MODEL FIRECOIL FIRE DOORS AS MANUFACTURED BY RAYNOR GARAGE DOORS.

BRACKETS- STEEL PLATES, MIN. 1/4"(6.4mm) THICK, BOLTED TO GUIDES FOR MOUNTING CURTAIN AND BARREL ASSEMBLY. DRIVE SIDE BRACKET SHALL BE FITTED WITH A SEALED BALL BEARING FOR LONG LIFE.

BARREL- STRUCTURAL STEEL PIPE, MINIMUM 4-1/2"(114.3mm) O.D.X120" (3.0mm) WALL THICKNESS AND DESIGNED TO LIMIT MAXIMUM DEFLECTION, UNDER LOAD, TO .03"(0.76mm) PER FOOT OF SPAN.

SPRING COUNTERBALANCE- THE CURTAIN SHALL BE COUNTERBALANCED BY MEANS OF OIL TEMPERED, HELICAL TORSION SPRINGS, GREASE-PACKED AND MOUNTED ON A SINGLE CONTINUOUS STEEL TORSION SHAFT. SPRINGS SHALL BE COMPRESSION SPRING DESIGN TO FACILITATE ANY COUNTERBALANCE MAINTENANCE. CAST IRON SPRING ANCHORS SHALL TRANSFER FULL SPRING LOADING TO THE BARREL.

HOOD- SHALL BE 24 GA. COMMERCIAL QUALITY HOT-DIPPED GALVANIZED STEEL. HOOD TO HAVE ROLLED EDGES TO PROVIDE RIGIDITY.

GUIDES- STRUCTURAL STEEL ANGLES, MIN. 3/16"(4.8mm) THICK. TOP OF GUIDE ANGLES FLARED AND PROVIDED WITH 4 REMOVABLE CURTAIN STOPS.

CURTAIN- INTERLOCKING SLATS ROLLFORMED FROM COMMERCIAL QUALITY HOT DIPPED GALVANIZED (G-90) STEEL PER ASTM A-653. FINISH SHALL BE TWO COAT BAKED ON PRIME PAINT APPLIED PRIOR TO ROLLFORMING. MALLEABLE IRON GALVANIZED ENDLOCKS FASTENED TO ALTERNATE SLATS WITH TWO ZINC PLATED STEEL RIVETS PER LOCK. ELIMINATES LATERAL MOVEMENT AND PREVENT SLATS FROM WEARING AT SURFACES COMING IN CONTACT WITH GUIDES. BOTTOM OF CURTAIN SHALL BE REINFORCED WITH TWO STEEL ANGLES, MINIMUM 2"x2"x3/16" (50.8mmX50.8mmX4.8mm).

JAMB CONSTRUCTION USING OTHER THAN MASONRY OR STRUCTURAL STEEL WRAPPED MASONRY MUST RECEIVE APPROVAL FROM LOCAL AUTHORITIES.

AUTOMATIC CLOSURE- AUTOMATIC CLOSING TO BE INITIATED BY MELTING A 165 DEGREE FUSIBLE LINK. OPERATION MECHANISM SHALL BE DISENGAGED DURING AUTOMATIC CLOSING OF THE DOOR. RATE OF DESCENT SHALL BE CONTROLLED BY A GOVERNOR.

DOOR(S) COMPLY WITH UNDERWRITERS LABORATORIES REQUIREMENTS FOR A 4-HOUR RATING.

- LOCKING- SLIDE BOLT TO ENGAGE GUIDE WITH PROVISION FOR PADLOCK. (PADLOCK BY OTHERS) QUANTITY REQUIRED
- LOCKING- FIVE PIN TUMBLER CYLINDER WITH LOCK BARS TO ENGAGE THE GUIDE. QUANTITY REQUIRED
- LOCK-OPERABLE FROM INTERIOR ONLY.
- LOCK-OPERABLE FROM EXTERIOR ONLY.

LEFT HAND DRIVE (SHOWN) "ELEVATION" RIGHT HAND DRIVE

DOOR NUMBER	QTY	OPENING		MODEL	GA.	"A"	"B"	"C"	"D"	"E"	"F"	"G"	"H"	"J"	MOUNT TYPE	OPER.	DRIVE	JAMB TYPE	GUIDE	JOB:		
		WIDTH	HEIGHT																			
																					DISTRIBUTOR:	
																						CONTRACTOR:
																						ARCHITECT:
																					NR:2902552	

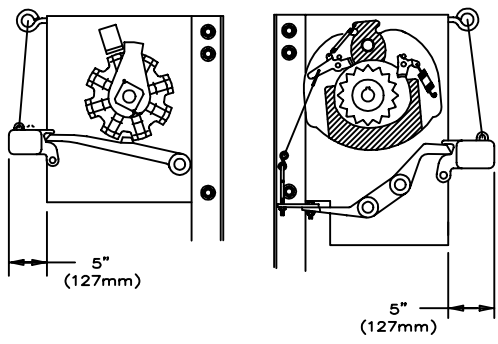

CHARGE HEADPLATE

DRIVE HEADPLATE

